

# FX-RLY Analog Contact Relay Module Installation Sheet

## Description

The FX-RLY Analog Contact Relay Module is an analog addressable device that provides one Form C dry relay contact. It can also be configured to provide polarity reversal of its output. The module can be used to control external appliances or shut down equipment.

The device address is set using the two rotary switches located on the front of the module. One device address is required.

The module is wired according to its operation, as shown in "Wiring" below. The module is configured to operate as a relay nonsilence device type from the factory. It can function as either a control relay or polarity reversal relay, depending on how it is wired.

**Control relay function:** Addressable device that provides one Form C dry relay contact. The system firmware ensures that the relay is in the proper state when powered up. Upon command from the control panel, the FX-RLY relay energizes.

**Polarity reversal relay function:** Addressable device that provides polarity reversal of its output. The system firmware ensures that the relay is in the proper state when powered up. Upon command from the control panel, the FX-RLY relay energizes, reversing the polarity of its output.

**Note:** Additional device types are available through front panel programming or the configuration utility. Refer to the applicable control panel technical reference manual.

## LED operation

The module provides a bicolor LED that shows its status.

Normal: Green LED flashes

Active: Red LED flashes

## Installation

Install and wire this device in accordance with applicable national and local codes, ordinances, and regulations.

**WARNING:** Connecting a device that exceeds this module's pilot duty contact ratings may cause activation failure. This module does not support capacitive loads. See "Specifications" on page 2 for contact ratings.

## Notes

- The module is shipped from the factory as an assembled unit; it contains no user-serviceable parts and should not be disassembled.
- This module will not operate without electrical power. As fires frequently cause power interruption, you should discuss further safeguards with your local fire protection specialist.
- This module does not support conventional smoke detectors.
- Install the module within the same room as the device it is controlling.

## To install the module:

1. Verify that all field wiring is free of opens, shorts, and ground faults.

2. Wire the module in accordance with "Wiring," Figure 3, and Figure 4.
3. Set the module address. Refer to the panel technical reference manual for a list of valid addresses.

Use a screwdriver to adjust the two rotary switches on the front of the module. Set the TENS rotary switch (0 through 12) for the 10s and 100s digit and the ONES rotary switch for the 0 through 9 digit. For example: device address 21, set TENS rotary switch to 2 and set the ONES rotary switch to 1 (see Figure 1).

4. Mount the module on the electrical box using screws provided with the electrical box (see Figure 2).
5. Mount the wall plate on the module using #4-24 x 1/2 self-tapping screws.

Figure 1: Module address

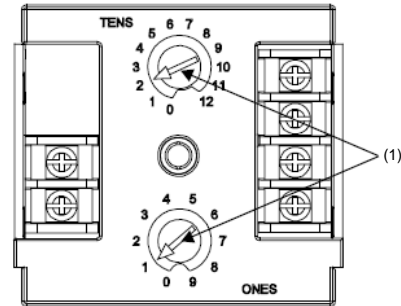

- (1) Address switch

Figure 2: Module installation

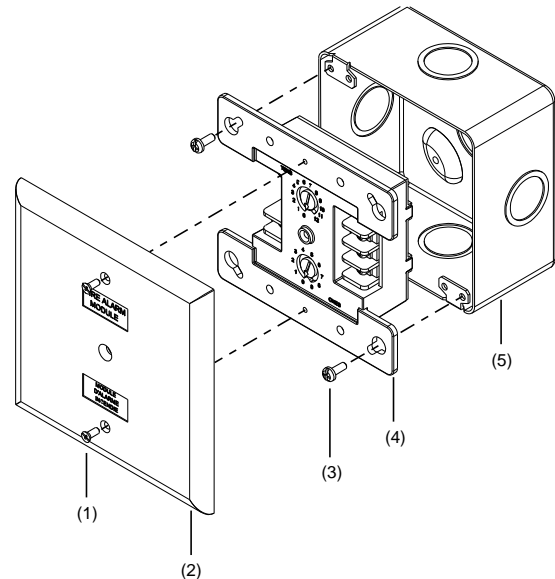

- (1) #4-24 x 1/2 self-tapping screw (4) Module  
 (2) Wall plate (5) Compatible electrical box  
 (3) Screw

## Wiring

Make all wiring connections as shown in Figure 3 or Figure 4 according to the desired function. Be sure to observe the polarity of the wires.

## Notes

- Only one conductor per terminal.
- The signaling line circuit (SLC) circuit is power-limited and supervised.
- Refer to the panel documentation for SLC wiring specifications.

**Figure 3: Control relay function**

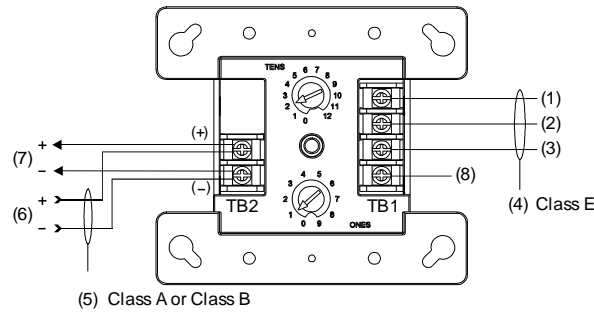

- (1) Normally closed contact (NC)
- (2) Normally open contact (NO)
- (3) Common contact
- (4) Power-limited unless connected to a nonpower-limited source. If the source is nonpower-limited, eliminate the power-limited mark and maintain a minimum of 0.25 in. (6.4 mm) space from power-limited wiring. For other mounting methods, see enclosure and bracket installation sheets to maintain separation of power-limited and nonpower-limited wiring. The wire size must be capable of handling fault current from nonpower-limited source.  
— or —

Use type FPL, FPLR, FPLP, or permitted substitute cables, provided these power-limited cable conductors extending beyond the jacket are separated by a minimum of 0.25 in. (6.4 mm) space or by a nonconductive sleeve or nonconductive barrier from all other conductors. Refer to the NFPA 70 *National Electrical Code* for more details.

- (5) All wiring is power-limited and supervised
- (6) Signaling line circuit (SLC) from previous device
- (7) Signaling line circuit (SLC) to next device
- (8) Not used

**Figure 4: Polarity reversal relay function**

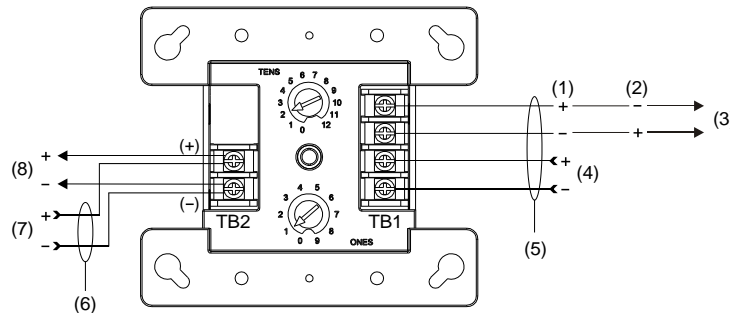

- (1) Normal
- (2) Active
- (3) Power out
- (4) Power in
- (5) Power-limited unless connected to a nonpower-limited source. If the source is nonpower-limited, eliminate the power-limited mark and maintain a minimum of 0.25 in. (6.4 mm) space from power-limited wiring. For other mounting methods, see enclosure and bracket installation sheets to maintain separation of power-limited and nonpower-limited wiring. The wire size must be capable of handling fault current from nonpower-limited source.  
— or —

Use type FPL, FPLR, FPLP, or permitted substitute cables, provided these power-limited cable conductors extending beyond the jacket are separated by a minimum of 0.25 in. (6.4 mm) space or by a nonconductive sleeve or nonconductive barrier from all other conductors. Refer to the NFPA 70 *National Electrical Code* for more details.

- (6) All wiring is power-limited and supervised
- (7) Signaling line circuit (SLC) from previous device
- (8) Signaling line circuit (SLC) to next device

## Specifications

Communication line voltage	Maximum 20.6 V peak-to-peak
Current	
Standby	125 $\mu$ A
Activated	125 $\mu$ A
Contact ratings (pilot duty)	
30 VDC	2 A
125 VAC	0.5 A resistive load 60 W or 62.5 VA max.
Relay type	Form C, programmable
Ground fault impedance	10 k $\Omega$
Compatible electrical boxes	4 in. square, 2-1/2 in. (64 mm) deep single-gang box 4 in. square, 2-1/2 in. (64 mm) deep double-gang box Standard 4 in. square, 1-1/2 in. (38 mm) deep box

## Specifications (continued)

Wire size	12, 14, 16, or 18 AWG wire (2.5, 1.5, 1.0, or 0.75 mm <sup>2</sup> ) (Sizes 16 and 18 AWG are preferred)
Operating environment	
Temperature	32 to 120°F (0 to 49°C)
Relative humidity	0 to 93%, noncondensing at 90°F (32°C)
Storage temperature range	-4 to 140°F (-20 to 60°C)

## Contact information

For contact information, see [www.kiddelivesafety.com](http://www.kiddelivesafety.com)

© 2017 Walter Kidde Portable Equipment, Inc.

All rights reserved.