

SIGA-HRD Intelligent Fixed-Temperature and Rate-of-Rise Heat Detector Installation Sheet

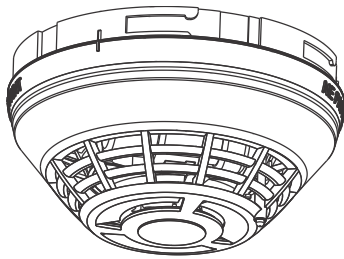

Description

The Signature Series model SIGA-HRD Intelligent Fixed-Temperature and Rate-of-Rise Heat Detector is an intelligent device that contains a rate-of-rise and fixed-temperature heat sensor function to detect fire. The heat sensor monitors the temperature of the surrounding air and the detector analyzes the data from the sensor to determine whether to initiate an alarm. The rate-of-rise heat function quickly detects a fast, flaming fire. The fixed-temperature heat function detects fire when the air temperature near the detector exceeds the alarm point.

LED indicator. The LED indicator (see Figure 1) displays the following states:

- Normal: Green LED indicator flashes, no action.
- Alarm/active: Red LED indicator flashes, evacuate the area.

Figure 1: SIGA-HRD features

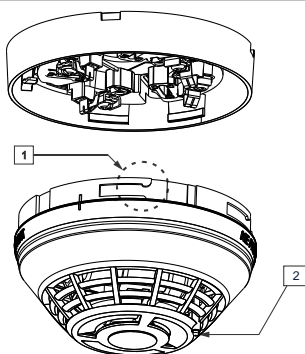

- (1) Self-locking tab
(2) LED indicator

Installation

Notes

- This detector does not operate without electrical power. As fires frequently cause power interruption, discuss further safeguards with the local fire protection specialist.
- This detector does not sense fires in areas where heat cannot reach the detector. Heat from fires in walls, roofs, or on the opposite side of closed doors may not reach the detector.

- This heat detector by itself does not provide life safety protection. Use this detector in conjunction with ionization or photoelectric smoke detectors, or both for life safety situations.
- This detector does not detect oxygen levels, smoke, toxic gases, or flames. Use this device as part of a broad-based life safety program which includes a variety of information sources pertaining to heat and smoke levels, extinguishment systems, visual and audible devices, and other safety measures.
- Independent studies indicate that heat detectors should only be used when property protection alone is involved. Never rely on heat detectors as the sole means of fire protection.
- To ensure proper operation, store the detector within the recommended ranges. Allow the detector to stabilize to room temperature before applying power.
- The dust cover (supplied) must remain on the detector during installation and be removed prior to commissioning and service. The dust cover is not a substitute for removing the detector during new construction or heavy remodeling.
- In Canada, install according to CAN/ULC-S524 *Standard for the Installation of Fire Alarm Systems*, CSA C22.1 *Canadian Electrical Code*, and the local authority having jurisdiction.

To install the detector:

1. Install and wire the base, as described on the installation sheet supplied with the base.
2. Remove the serial number label from the detector and attach it to the project documentation.
3. Attach the detector to the base by rotating the detector clockwise until it snaps into the locked position.

Testing

Before testing, notify the proper authorities that the fire alarm system is undergoing maintenance and will be temporarily out of service.

Caution: Heat damage. Excessive heat may damage the detector outer cover. Do not apply excessive heat when using a hair dryer. When using a Testifire detector tester, you must install a SIGA2 Testifire Adapter Assembly.

Make sure the SIGA2 Testifire Adapter Assembly (model SIGA2-TSTSPACER) is installed in the Testifire detector tester before testing. Refer to the *SIGA2-TSTSPACER Testifire Adapter Assembly Installation Sheet* (P/N 3101942-ML) for further details.

To perform an initial installation test:

1. Visually inspect each detector and verify that it is installed in the correct location. Make sure it is not adversely affected by factors not apparent on the plans.
2. Remove the detector from its base and verify that the proper detector address, trouble signals, and messages are reported.
3. If wired for Class A operation, verify that the detector continues to operate first with the SLC_IN disconnected, and then with the SLC_OUT disconnected. (Refer to the installation sheet for the base.)
4. Place a momentary ground fault on the SLC circuit to verify operation of the ground fault detection circuitry.
5. Perform a sensor function test, as described below.

To perform a function test:

1. If desired, use the fire alarm control panel to put the detector or zone into a service group for testing. (Refer to the panel technical reference manual for instructions.)

2. Activate the heat sensor using a hair dryer (maintaining a distance of three inches) or using a Testfire detector tester per the manufacturer's instructions.

Maintenance

To ensure proper operation, plan maintenance (regular or selected) of the detector in accordance with the AHJ and all applicable governing laws, codes, or standards. Refer to CAN/ULC-S536 *Standard for the Inspection and Testing of Fire Alarm Systems* and NFPA 72 *National Fire Alarm and Signaling Code*.

Refer to application bulletin P/N 3102403-EN for additional information and cleaning instructions.

Specifications

Operating voltage	15.20 to 19.95 VDC
Current	
Normal operating	51 μ A
Alarm	68 μ A
Vibration level	10 to 35 Hz, with an amplitude of 0.01 in.
Rate-of-rise	15°F/min (8°C/min)
Maximum spacing [1]	50 ft. (15.2 m) centers
Compatible bases	
Standard	SIGA-SB, SIGA-SB4
Relay	SIGA-RB, SIGA-RB4
Isolator	SIGA-IB, SIGA-IB4
Audible	SIGA-AB4G, SIGA-AB4GT, SIGA-AB4G-LF
Compatible detector testers [2]	Testfire 1000, Testfire 2000
Operating environment	
Temperature	32 to 100°F (0 to 38°C)
Relative humidity	0 to 93% noncondensing
Storage temperature	-4 to 140°F (-20 to 60°C)

[1] When replacing SIGA-HRS and SIGA-HFS detectors with the SIGA-HRD, ensure that the spacing is 50 ft. (15.2 m) or less.

[2] Requires the SIGA2-TSTSPACER Testfire adapter assembly.

Regulatory information

North American standards	CAN/ULC-S530, UL 521
UL/ULC fixed-temp alarm rating	135°F (57.2°C)
UL/ULC Actual alarm point	129 to 141°F (53.9 to 60.6°C)
Response time index	Quick(evaluated by FM Approvals)
FCC compliance	This device complies with part 15 of the FCC Rules. Operation is subject to the following two conditions: (1) This device may not cause harmful interference, and (2) this device must accept any interference received, including interference that may cause undesired operation.
Industry Canada compliance	This Class A digital apparatus complies with Canadian ICES-003.

Contact information

For contact information, see www.edwardsfiresafety.com