

KI-PHD Intelligent Multisensor Photo-Heat Detector Installation Sheet

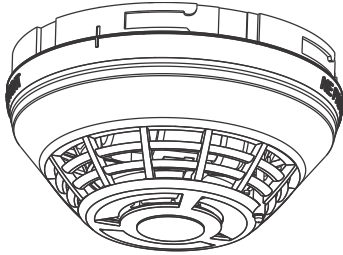

Description

The model KI-PHD Intelligent Multisensor Photo-Heat Detector is an intelligent device that contains a photoelectric smoke sensor and a rate-of-rise heat sensor with a fixed temperature setting. The detector analyzes the data from both sensing devices and determines whether an alarm should be initiated. Can be operated as a single detector using smoke or heat to initiate an alarm or as a split sensor with heat and smoke initiating separate signals.

LED indicator. The LED indicator (see Figure 1 below) displays the following states:

- Normal: Green LED indicator flashes, no action.
- Alarm/active: Red LED indicator flashes, evacuate the area.

Installation

Notes

- This detector does not operate without electrical power. As fires frequently cause power interruption, discuss further safeguards with the local fire protection specialist.
- This detector does not sense fires in areas where smoke or heat cannot reach the detector. Smoke or heat from fires in walls, roofs, or on the opposite side of closed doors may not reach the detector.
- Photoelectric detectors have a wide range of sensing capabilities, and are best suited for detecting slow, smoldering fires. The heat sensor in this device provides a source of supplemental information. The heat sensor by itself does not provide life safety protection.
- To ensure proper operation, store the detector within the recommended ranges. Allow the detector to stabilize to room temperature before applying power.
- The dust cover (supplied) must remain on the detector during installation and be removed prior to commissioning and service. The dust cover is not a substitute for removing the detector during new construction or heavy remodeling.
- Do not use smoke detectors with detector guards unless the combination has been evaluated and found suitable.
- In Canada, install according to the CAN/ULC-S524 *Standard for the Installation of Fire Alarm Systems*, the CSA C22.1 *Canadian Electrical Code*, and the local authority having jurisdiction.

- Upon completion of the original installation and following any modifications or additions to the system, perform a calibrated sensitivity test per NFPA code. These devices can perform this test and the panel can generate a system sensitivity report.

To install the device:

1. Install and wire the base, as described on the installation sheet supplied with the base.
2. Remove the serial number label from the detector and attach it to the project documentation.
3. Attach the detector to the base by rotating the detector clockwise until it snaps into the locked position.

Figure 1: KI-PHD features

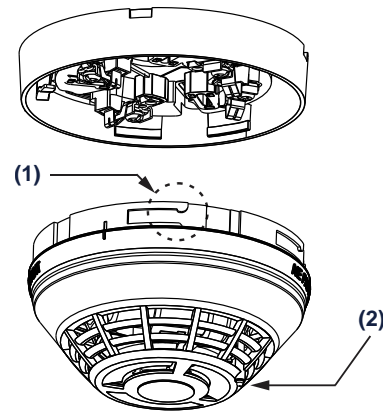

- (1) Self-locking tab
- (2) LED indicator

Testing

Before testing, notify the proper authorities that the fire alarm system is undergoing maintenance and will be temporarily out of service.

Test each sensor in the detector.

Caution: Heat damage. Excessive heat may damage the detector outer cover. Do not apply excessive heat when using a hair dryer. When using a Testfire detector tester, you must install a Testfire Adapter Assembly.

Make sure the Testfire Adapter Assembly (model K-TSTSPACER) is installed in the Testfire detector tester before testing. Refer to the *Testfire Adapter Assembly Installation Sheet* (P/N 3102495-ML) for further details.

To perform an initial installation test:

1. Remove the detector from its base and verify that the proper detector address, trouble signals, and messages are reported.
2. For KI-PHD detectors placed in the air ducts, verify that the airflow is within specifications. See "Specifications" on page 2.
3. If wired for Class A operation, verify that the detector continues to operate first with SLC_IN disconnected, and then with SLC_OUT disconnected. (Refer to the installation sheet for the base.)
4. Place a momentary ground fault on the SLC circuit to verify operation of the ground fault detection circuitry.
5. Run a system detector sensitivity report on all detectors and verify that readings fall within acceptable limits.
6. Perform a sensor function test, as described below.

To perform sensor function tests:

1. If desired, use the fire alarm control panel to put the detector or zone into a service group for testing. (Refer to the panel technical reference manual for instructions.)
2. Activate the smoke sensor using No Climb Products model Smoke Centurion/M8, FireTech Smoke or Smoke Sabre smoke aerosol spray, a smoke generator, or the Testifire detector tester per the manufacturer's instructions.
3. Activate the heat sensor using a hair dryer (maintaining a distance of three inches) or using a Testifire detector tester per the manufacturer's instructions.

Maintenance

To ensure proper operation, plan maintenance (regular or selected) of the detector in accordance with the AHJ and all applicable governing laws, codes, or standards. Refer to CAN/ULC-S536 *Standard for the Inspection and Testing of Fire Alarm Systems* and NFPA 72 *National Fire Alarm and Signaling Code*.

Refer to Application Bulletin P/N 3102483-EN for additional information and cleaning instructions.

Specifications

Operating voltage	15.20 to 19.95 VDC
Current	
Normal operating current	51 µA
Alarm	68 µA
Vibration level	10 to 35 Hz, with an amplitude of 0.01 in.
Rate-of-rise	15°F/min (8°C/min)
Air velocity [1]	0 to 4,000 ft./min (0 to 20.32 m/s)
Maximum spacing for Heat Detectors [3]	50 ft. (15.2 m) centers
Wall mount distance from ceiling	12 in. (305 mm) max.
Compatible bases	
Standard	KI-SB, KI-SB4, GSA-SB, GSA-SB4
Relay	KI-RB, KI-RB4, GSA-RB
Isolator	KI-IB, KI-IB4, GSA-IB, GSA-IB4
Audible	KI-ABST, KI-ABDT, KI-ABLT GSA-SBT, GSA-AB4G
Compatible detector testers [2]	Testifire 1000, Testifire 2000
Operating environment	
Temperature	32 to 100°F (0 to 38°C)
Relative humidity	0 to 93% noncondensing
Storage temperature	-4 to 140°F (-20 to 60°C)
Environmental compensation	Automatic

[1] For duct installation, use a K-DMP duct detector mounting plate and install per P/N 3102482-EN.

[2] Requires the K-TSTSPACER Testifire adapter assembly.

[3] When replacing GSA-HRS and GSA-HFS detectors with the KI-PHD, ensure that the spacing is 50 ft. (15.2 m) or less.

Regulatory information

North American standards	CAN/ULC-S529, CAN/ULC-S530, UL 268, UL 268A, UL 521
UL/ULC smoke sensitivity range	0.53 to 3.94 %/ft. (1.7 to 12.35 %/m) obscuration
UL/ULC fixed-temperature alarm rating	135°F (57.2°C)
UL/ULC Actual alarm point	129 to 141°F (53.9 to 60.6°C)
FCC compliance	This device complies with part 15 of the FCC Rules. Operation is subject to the following two conditions: (1) This device may not cause harmful interference, and (2) this device must accept any interference received, including interference that may cause undesired operation.
Industry Canada compliance	This Class A digital apparatus complies with Canadian ICES-003.

Contact information

For contact information, see www.kiddlifesafety.com.